

MV

VERTICAL MIXED FLOW PUMPS

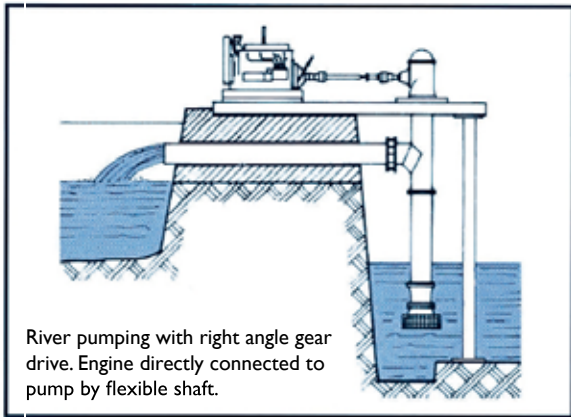

River pumping with right angle gear drive. Engine directly connected to pump by flexible shaft.

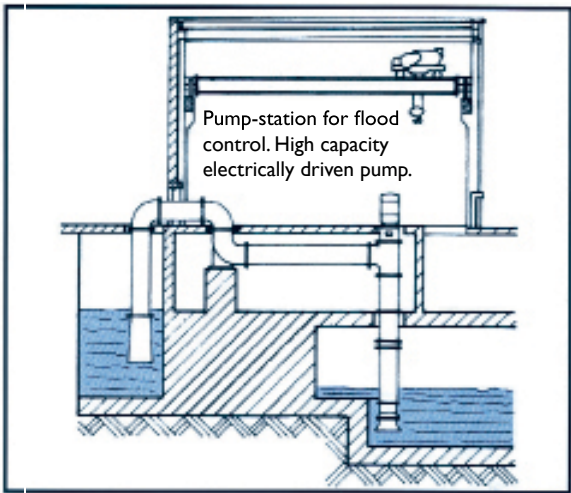

Pump-station for flood control. High capacity electrically driven pump.

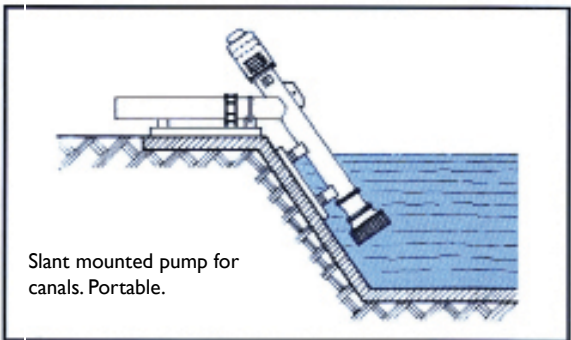

Slant mounted pump for canals. Portable.

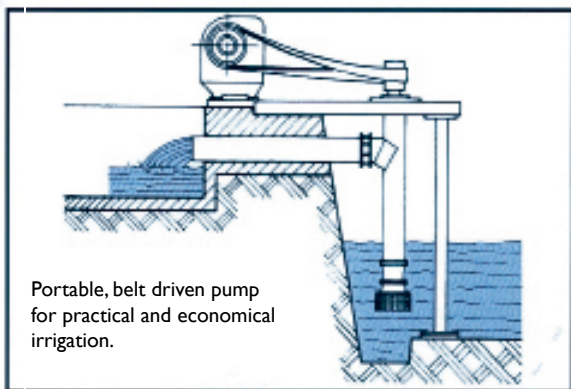

Portable, belt driven pump for practical and economical irrigation.

The MV type pumps are mixed flow pumps of single or multi-stage design. Standardized assembly groups: bowl, column, discharge head and driver. Capacity appr. 130 to 23000 m³ / h. Total head up to 250 m. Discharge branch sizes NW 200 to 1600 mm. For larger capacities refer to the factory. Usually the mixed flow pumps are installed in a vertical position taking suction from an open sump and discharging through a 90 degree elbow. They can be mounted, if necessary, horizontally. It is also quite common to lay the pump at an angle on a level or ditch bank. This reduces the cost of the supporting structure.

DESIGN FEATURES

Space Saving

Vertical arrangement saves valuable floor space.

Self Priming

Submerged impellers allow pump to be started without priming. Low initial and operating cost.

Low Operating Cost

High efficiency pump design and high reliability result in lower operating cost.

Long Life – Low Maintenance

Flanged bowls and column pipes for easier assembly – disassembly and perfect alignment.

Design Flexibility

Single or multistage construction with enclosed or semi-open impellers of different design and sizes. Oil, grease, clean or pumped water lubrication. Height adjustable with standard column parts. Four types of discharge heads to meet specific requirements. Discharge elbow under or over floor.

Driven by electric motor, diesel engine, directly or through a right angle gear drive or belt.

CODE DESIGNATION

1	2	3	4	5	6	7
---	---	---	---	---	---	---

- | | |
|---|---|
| <ol style="list-style-type: none"> 1. Pump size in mm 2. Number of stages 3. Column size in mm 4. Discharge Head
 A (BBE) type A (Below Base Elbow)
 A (ABE) type A (Above Base Elbow)
 B type B
 C type C
 D type D 5. Pump Axial thrust
 HS Hollow Shaft
 STB Separate Thrust Bearing 6. Driving
 EM Electric Motor
 RAGD Right Angle Gear Drive
 PD Pulley Drive 7. Lubrication
 GL Grease, CWL Clean Water
 PL Product
 OL Oil | <p>Example:
MV 310 BL – 3 – 300 – A (BBE) – HS – EM – OL</p> <p>Standard vertical mixed flow multistage pump.
Nominal pump size MV 310 BL.
Three (3) stages.
Column size 300mm.
Discharge head type “A” (BBE).
Hollow shaft – Electric motor.
Oil Lubrication</p> |
|---|---|

SPECIFICATIONS

SUCTION STRAINER

A heavy galvanized strainer, bolted securely to the suction bell, prevents foreign materials from entering the pump.

BOWL ASSEMBLY

It consists of the suction bell, intermediate bowls for multistage pumps and the discharge bowl. The bowls are flanged. The suction bell with entrance guide vanes prevents prerogation. The discharge bowl with diffusion vanes properly directs the flow of the water into the discharge column. Pump shaft of stainless steel. Suction and discharge bronze bearing supporting the pump shaft above and below the impeller ensure vibration free operation. Rubber intermediate bowl bearing available for multistage pumps. The suction bearing is protected by a bronze sand collar; similarly for discharge bearing of water or grease lubricated pumps.

The mixed flow impellers, enclosed (type B, E, KQM, KRM, XVF) or semi-open (type D, F, KMa, Xk), are secured firmly to the shaft by means of a key and a split thrust ring or by a taper collet for small pump sizes. Wear rings are available in the bowls and optionally in the impellers. As option (especially in large pumps) design with separate impeller ring is available.

ROTATION

Counter-clockwise when viewed from above.

COLUMN ASSEMBLY

The column and discharge elbow direct the flow from bowl assembly to the discharge piping. Column pipes are constructed of concentric flanged steel pipes. The column pipe flanges and bearing retainers are machined to form close tolerance for perfect alignment and concentricity. Column shafts are made of carbon steel for oil lubricated pumps and of stainless steel or carbon steel with sleeves of stainless steel at bearing positions for water and grease lubricated pumps. The column shafts are guided in water lubricated rubber bearings or in grease or oil lubricated bronze bearings. They are spaced at a length such that the operating speed will not be more than 80% of the first critical speed. Cast iron bearing retainers for water and greased lubricated pumps. Construction with shaft enclosing tubes and clean water or oil lubrication is available where protection from the pumping medium is required. The steel enclosing tube is held rigidly in position by a bronze tension nut. Properly spaced tube stabilizers of cast iron are available for oil lubricated pumps.

DISCHARGE HEAD

Structural versions: Fabricated steel type "A" and "B" with discharge elbow, fabricated steel type "C" and cast iron type "D". The weight of column pipes and pump is carried by the baseplate of the discharge head. Driver mounting flange machined to NEMA standards to accept any vertical drive arrangement.

The standard discharge head is the type "A". The elbow for type "A" is integral with the baseplate and can be either above (ABE) or below (BBE) it, depending on the installation requirements. Elbow below base is usually preferred as its lower centre of gravity makes for more stable pump and motor. Normally the elbow discharge is horizontal (at 90 degrees to the pump shaft), but other angles can also be supplied when required. The elbows are made from standard steel pipes, electrically welded. The standard elbow is made with one 45 degree section. Long sweep elbows with five intermediate sections can also be supplied.

Head-Shaft : Standard two – piece head-shaft arrangement with head-shaft coupling immediately above stuffing box. Head-shaft is made of stainless or carbon steel with sleeve of stainless steel at stuffing box position.

Stuffing box: The water and grease lubricated pumps are furnished with a packed stuffing box. Bronze split gland can be completely removed from the pump for easy packing replacement without disassembly. Mechanical seal is available upon request.

In oil lubricated pumps, the leakage between tension nut body and tube protective sleeve is positively prevented by O-ring seal.

DRIVERS

Vertical electric motors are generally connected directly to the pump. With hollow shaft motors, the pump downthrust is carried by a thrust bearing built into the motor. The drive shaft extends up through the motor shaft and is properly secured at the top. With solid shaft motors, the headshaft is connected to a heavy ball bearing thrust assembly, located on the pump base plate.

Horizontal electric motors or internal combustion engines are connected to the pump through suitable right angle gear drive or belt drive.

LUBRICATION

Oil lubrication : Oil is supplied to bronze line shaft bearings by an oiler, secured on the motor base. Oiler can be hand operated or solenoid for automatic lubrication. The suction bell bearing is packed with water resistant grease, ensuring a long period of operation.

Grease lubrication: Grease is supplied to bronze lineshaft bearings by a grease pump, secured on the motor base.

Water lubrication: line-shaft bearings are lubricated by the pumped water; bearings are made of Special Rubber in standard construction or can be from special synthetic material upon request. The suction bell bearing is grease lubricated. This type of lubrication is recommended for clear water to avoid oil contamination. The pump should not be dry, as the rubber bearings will seize. In case of turbid pumped water, clean water from an external source can be supplied to the line-shaft bearings through shaft enclosing tubes.

PERFORMANCE RANGE

STANDARD CONSTRUCTION

TYPE MV - B

N=1450 RPM

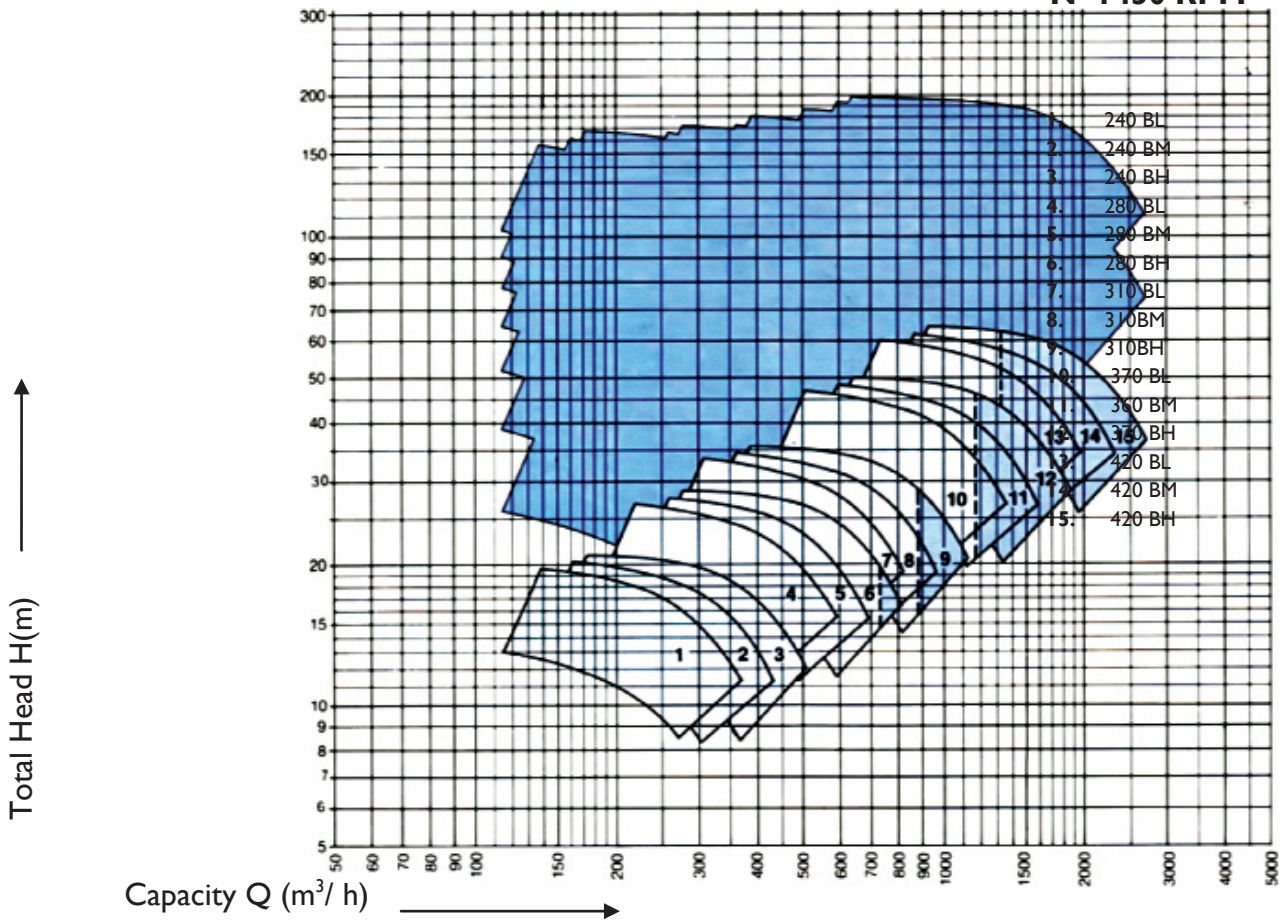

TYPE MV - E

N=1450 RPM

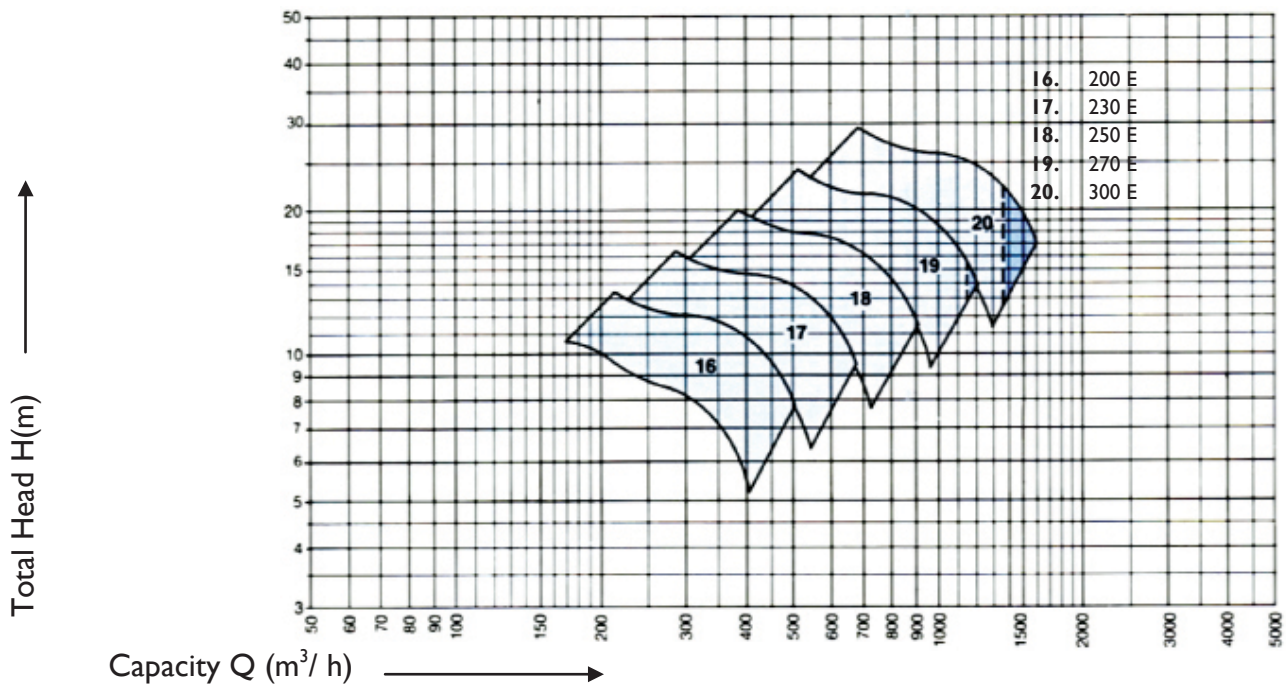

PERFORMANCE RANGE

STANDARD CONSTRUCTION

TYPE MV - F

N=1450 RPM

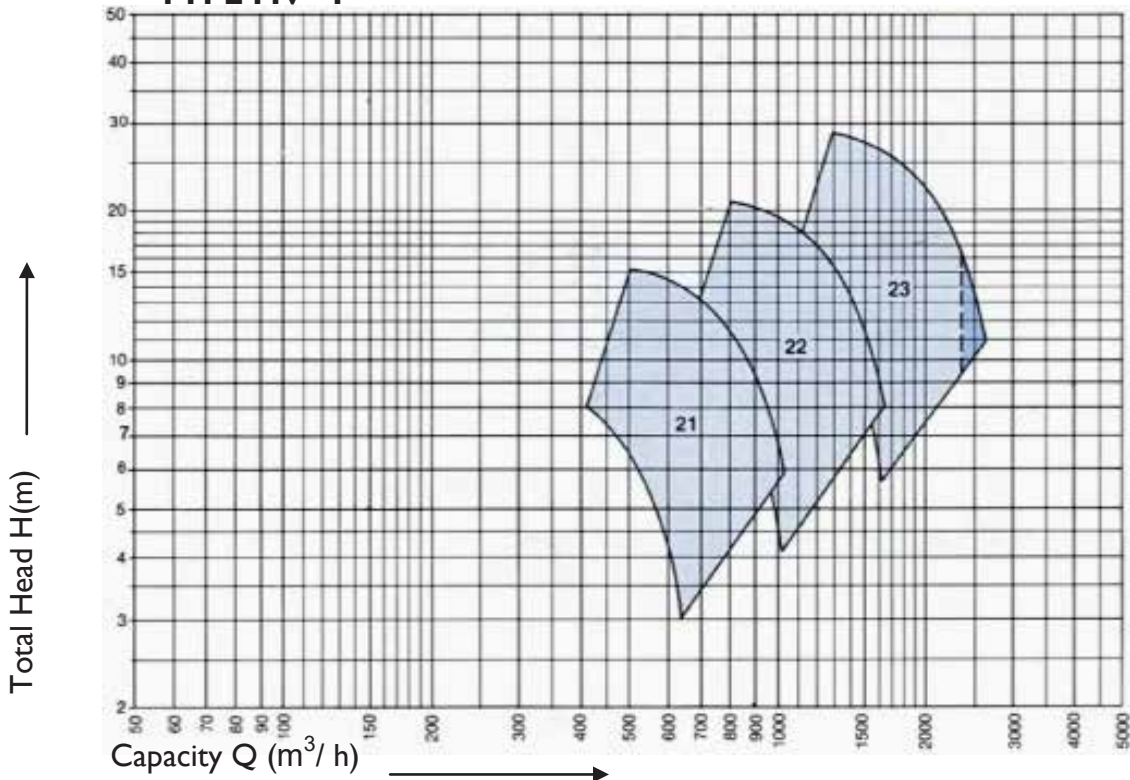

- 21. 230 F
- 22. 260 F
- 23. 310 F

NOTES : 1) Light blue area represents one-stage performance.
 2) Medium intensity blue indicates range where NPSH is greater than 10m
 3) Blue area represents performance range with maximum number of stages

EXTENDED RANGE

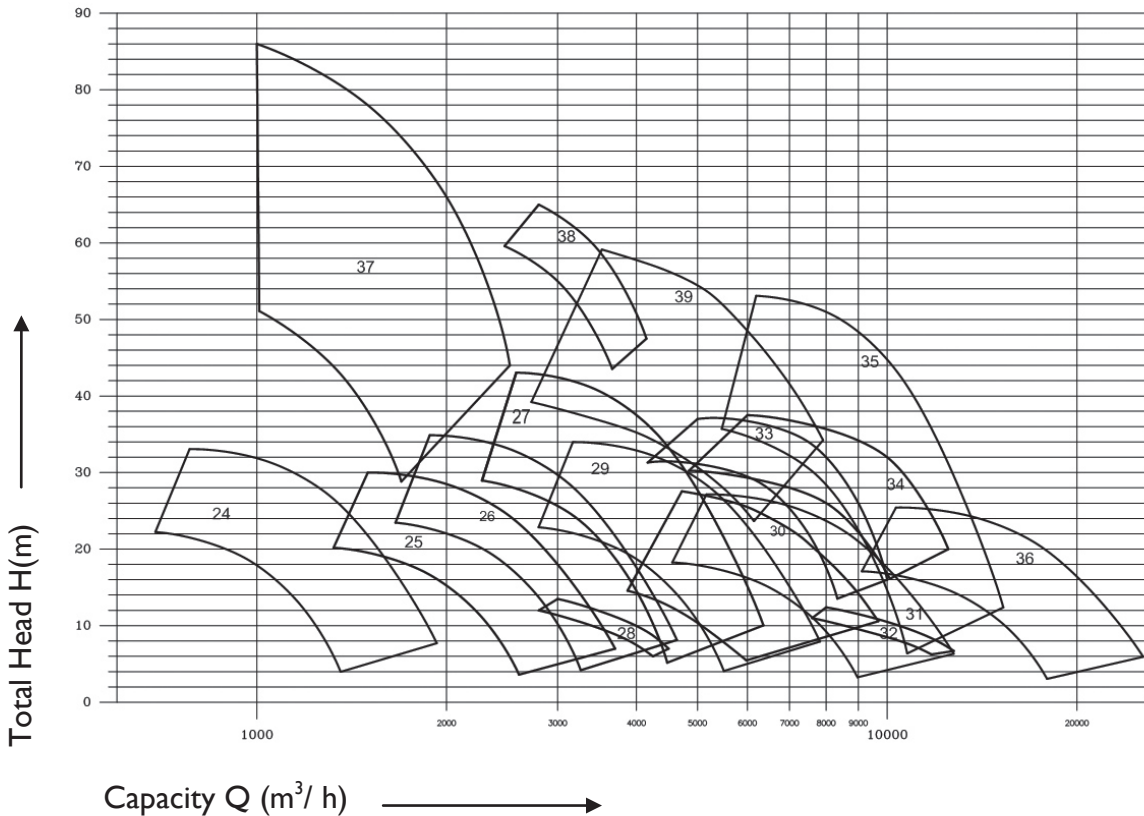

- 24. 340 D (1460 rpm)
- 25. 480 D (980 rpm)
- 26. 500 DL (980 rpm)
- 27. 580 D (980 rpm)
- 28. 500 KMa (980 rpm)
- 29. 680 D (740 rpm)
- 30. 590 F (740 rpm)
- 31. 920 D (490 rpm)
- 32. 850 KMa (490 rpm)
- 33. 820 KQM (740 rpm)
- 34. 850 KQM (740 rpm)
- 35. 850 D (740 rpm)
- 36. 1320 D (330 rpm)
- 37. 560 KRM (1460 rpm)
- 38. 700 KRM (980 rpm)
- 39. 830 BL (740 rpm)

NOTES : 1) Higher capacities upon request.
 2) Performance per stage.

SECTIONAL VIEWS

ENCLOSED LINE SHAFT

CLEAN WATER LUBRICATION

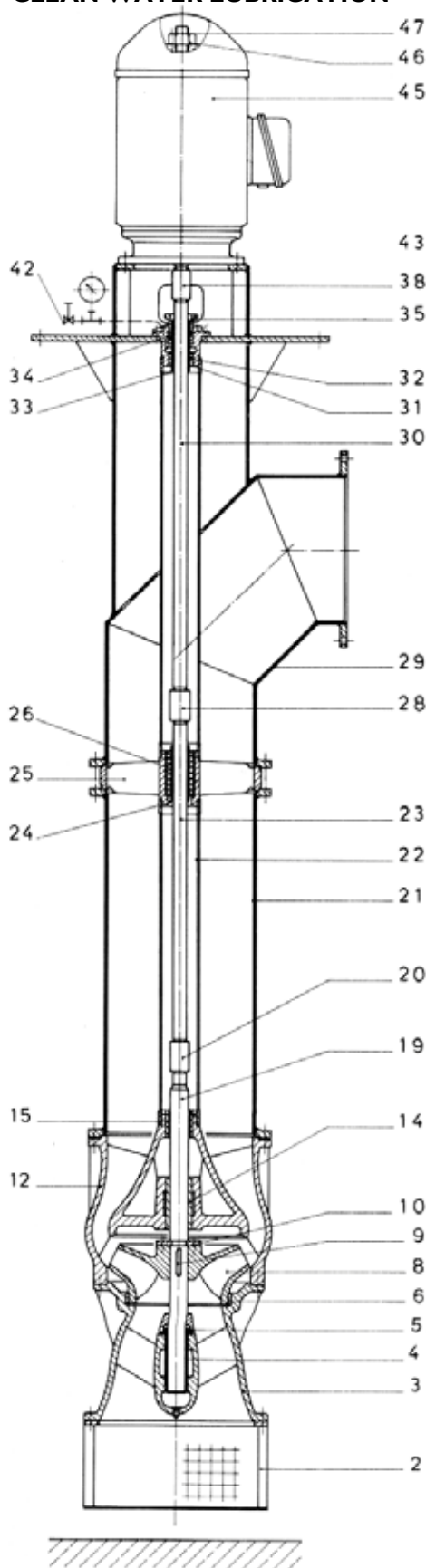

OIL LUBRICATION

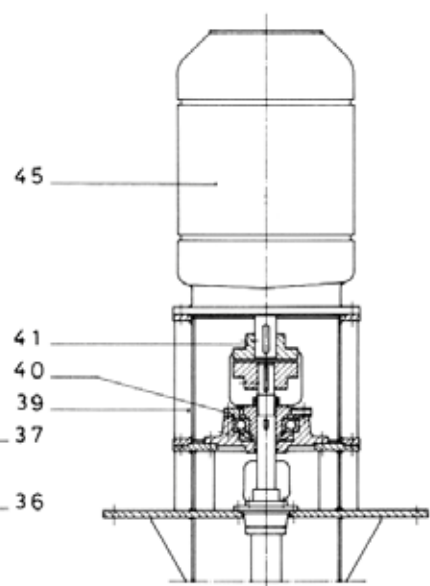
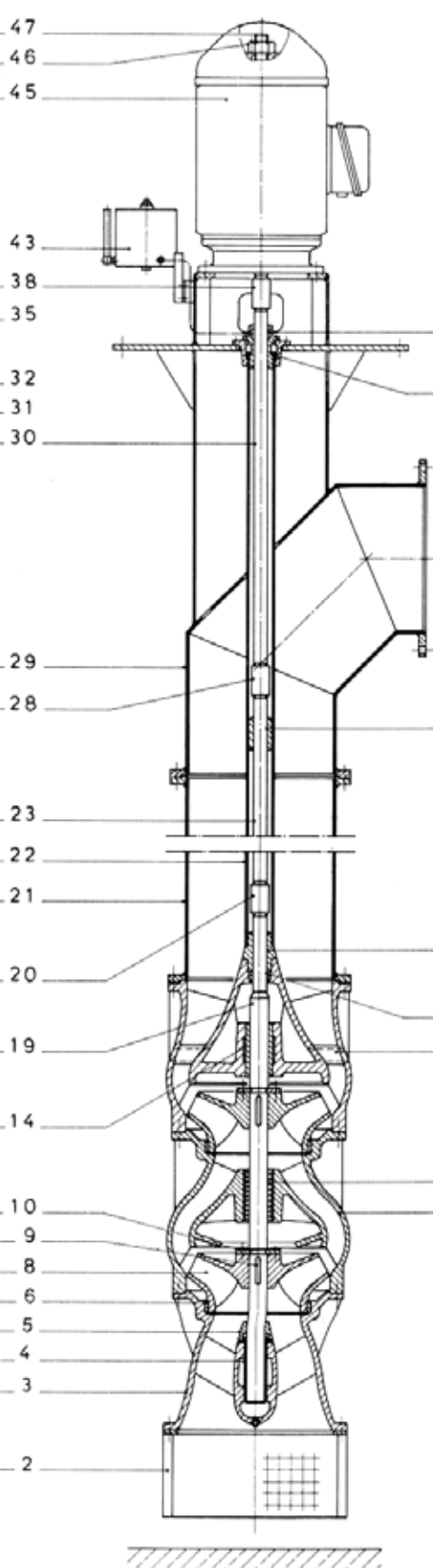

Solid shaft motor.
Flexible coupling.
Separate axial
Thrust bearing

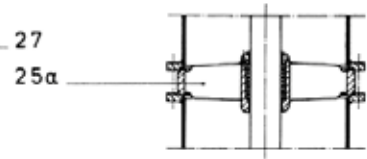

Tube stabilizer.

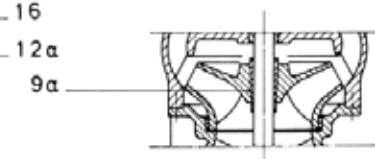

Impeller with
taper collet.

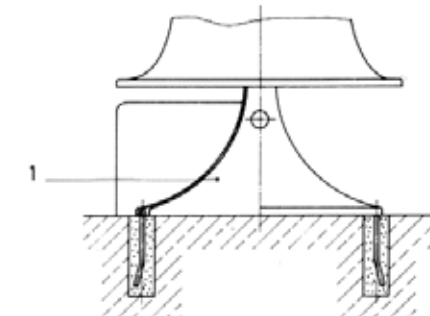

Entry cone to approve
suction approach.

PART LIST

OPEN LINE SHAFT

Grease or Pumped Water Lubrication

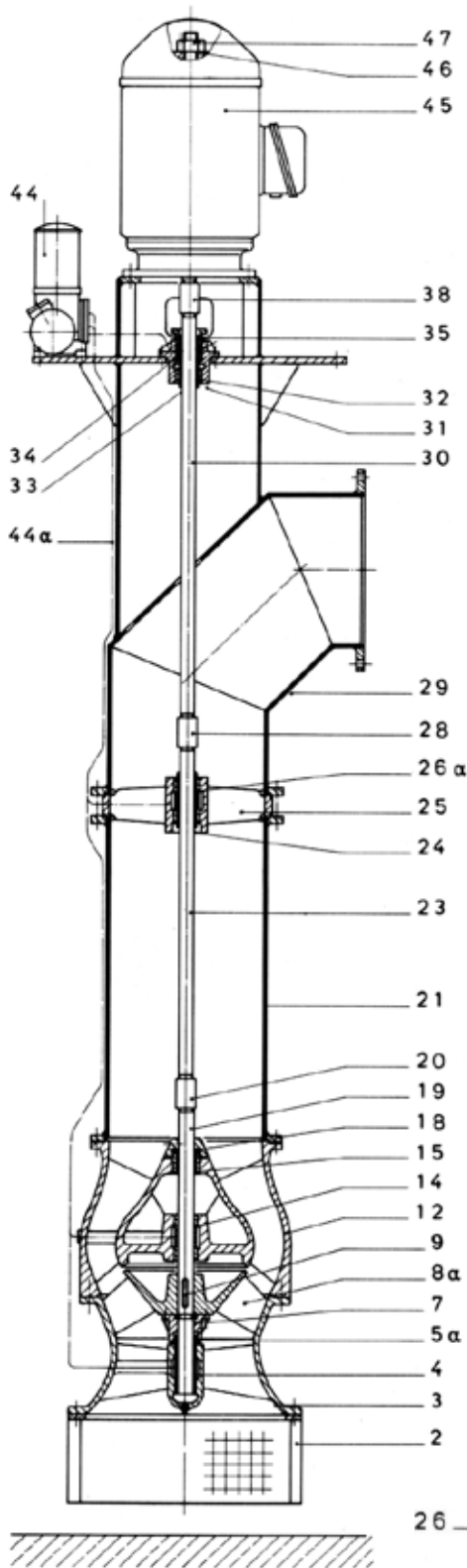

ITEM NUMBER	CODE NUMBER	PART NAME	STANDARD MATERIAL OF CONSTRUCTION
1	50	Entry Cone	Cast Iron GG - 20
2	155	Strainer	Galvanize steel
3	138	Suction Bell	Cast Iron GG - 20
4	545.1	Suction Bell Bearing	Bronze Rg 7
5	271.1	Sand Collar	Bronze Rg 5
5a	271.2	Sand Collar for semi-open Impeller	Bronze Rg 5
6	502	Bowl Wear Ring	Cast Iron GG - 20
7	501.1	Split Ring for Axial Thrust	Stainless steel X20Cr13
8	230.1	Impeller (enclosed)	Bronze Rg 5
8a	230.2	Impeller (semi-open)	Bronze Rg 5
9	940	Impeller Key	Stainless steel X20Cr13
9a	943	Impeller Taper Collet	Stainless steel X20Cr13
10	501.2	Split Ring	Stainless steel X20Cr13
11	112	Intermediate Bowl	Cast Iron GG - 20
12	112.1	Discharge Bowl	Cast Iron GG - 20
12a	112.2	Discharge Bowl for O.L.	Cast Iron GG - 20
13	545.2	Intermediate Bowl Bearing	Rubber 45-55 shore
14	545.3	Discharge Bowl Bearing	Bronze Rg 7
15	545.4	Discharge Bowl Bearing	Bronze Rg 7
16	421	Sealing Rings for O.L.	
17	544	Tube Adaptor Bearing	Bronze Rg 7
18	271.3	Sand Collar	Bronze Rg 5
19	211	Pump Shaft	Stainless steel X20Cr13
20	852.1	Pump Shaft Coupling	Steel St 70-2
21	711	Column Pipe	Steel St 37-2
22	714	Shaft Enclosing Tube	Steel St 35
23	212	Column Shaft	Steel Ck 45 or Stainless steel X20Cr13
24	524.1	Column Shaft Sleeve	Stainless steel X20Cr13
25	383	Bearing Retainer for G.L., C.W.L. & P.L.	Cast Iron GG - 20
25a	717	Tube Stabilizer	Cast Iron GG - 20
26	545.5	Column Shaft Bearing for C.W.L. & P.L.	Rubber 45-55 shore
26a	545.6	Column Shaft Bearing for G.L.	Bronze Rg 7
27	544.1	Tube Shaft Bearing for O.L.	Bronze Rg 7
28	852.2	Column Shaft Coupling	Steel St 70-2
29	115.1	Discharge Head type A (BBE)	Steel USt 37-2
29a	115.2	Discharge Head type A (ABE)	Steel USt 37-2
29b	115.3	Discharge Head type B	Steel USt 37-2
29c	115.4	Discharge Head type C	Steel USt 37-2
29d	115.5	Discharge Head type D	Steel USt 37-2
30	213.1	Headshaft	Steel Ck 45 or Stainless steel X20Cr13
31	451	Stuffing Box Casing	Cast Iron GG - 20
32	545.7	Stuffing Box Bearing	Bronze Rg 7
33	524.2	Headshaft Sleeve	Stainless steel X20Cr13
34	461	Stuffing Box Packing	Graphitized Asbestos
35	452	Stuffing Box Gland	Cast Iron GG - 20
36	465	Tension Nut Body for O.L.	Cast Iron GG - 20
37	466	Tension Nut for O.L.	Bronze Rg 7
38	852.3	Headshaft Coupling	Steel St 70-2
39	341	Drive Adaptor	Steel USt 37-2
40	303	Thrust Bearing Assembly	
41	843	Flexible Coupling	
42		Clean Water Supply Device for C.W.L.	
43	633	Oiler for O.L.	
44	634	Grease Pump for G.L.	
44a	707	Grease Tubes	Copper
45	800	Electric Motor (or Right Angle Gear Drive or Pulley Drive)	
46	921	Adjusting Nut	Steel Ck 35
47	213.2	Drive Shaft	Steel Ck 45 or Stainless Steel X20Cr13

Pumped Water Lubrication

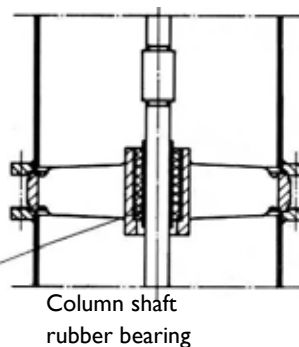

MATERIAL CROSS REFERENCE

DIN Designation	DIN Number	USA Designation
GG - 20	0.6020	A48 Class 30
X20Cr13	1.4021	AISI 420
Ck35	1.1181	AISI 1035
Ck45	1.1191	AISI 1045
St 35	1.0308	
St 60-2	1.0543	
St 70-2	1.0633	
St 37-2	1.0112	
USt 37-2	1.0036	A 570 Gr 33.36
Rg 5 (CuSn5 ZnPb)	2.1096.01	SAE 40
Rg 7 (CuSn7 ZnPb)	2.1090.01	SAE 660

AVAILABLE CASTINGS MATERIAL & SPECIFICATIONS

	TYPE	DESCRIPTION	DIN Designation	DIN Number	EN Designation	USA Designation
Castings	Cast Iron	Grey Cast Iron	GG-20	0.6020	EN-JL1030	A48 Class 30
		Grey Cast Iron	GG-25	0.6025	EN-JL1040	A48 Class 40
		Ductile Iron	GGG40.3	0.7043	EN-JS1025	A536 60-40-18
		Ni-Resist	GGG-NiCrNb 20 2	0.7661	EN-GJS-AXNiCrNb20-2	A571 D-2
	Bronze	Tin-Lead Bronze	G-CuSn5Zn5Pb5	2.1096	EN-1982-G-CuSn5Zn5Pb5	B62 C83600
		Zinc-Free Bronze	G-CuSn10	2.1050	EN-1982-G-CuSn10	
		Ni-Al Bronze	G-CuAl10Ni5Fe4		EN-1982-G-CuAl10Ni5Fe4	
	Cast Steel	Non alloy steel	GS-45	1.0446	EN-10293-GE240	A 27 (65-35)
		Non alloy steel	GS-52	1.0552	EN-10293-GE260	A 27 (70-40)
		Structural Steel	GP240GH	1.0619	EN 10213-2-GP240GH	A216 (WCB)
	Stainless Steel	Austenitic (316)	GX5CrNiMo19-11-2	1.4408	EN-10283-GX5CrNiMo19-11-2	A351 (CF8M)
		Austenitic (316L)	GX2CrNiMo19-11-2	1.4409	EN-10283-GX2CrNiMo19-11-2	A351 (CF3M)
		Full Austenitic (904L)	GX2NiCrMoCu25-20-5	1.4584	EN-10283GX2NiCrMoCu25-20-5	~AISI-904L
		Duplex	GX2CrNiMoCuN25-6-3-3	1.4517	EN-10283-GX2CrNiMoCuN25-6-3-3	A890 (CD4MCuN)
		Super Duplex	GX2CrNiMoN26-7-4	1.4469	EN-10283-GX2CrNiMoN26-7-4	A890 (CE3MN)

DISCHARGE HEADS

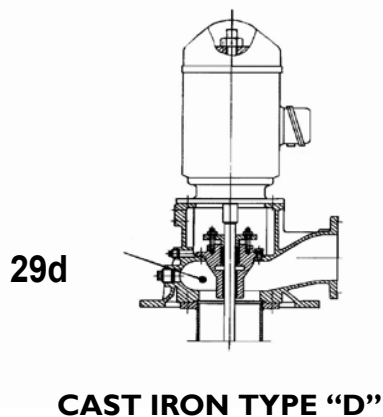
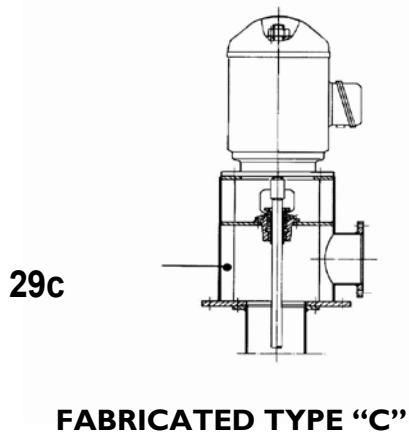
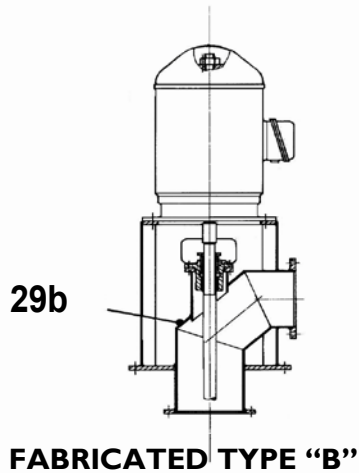
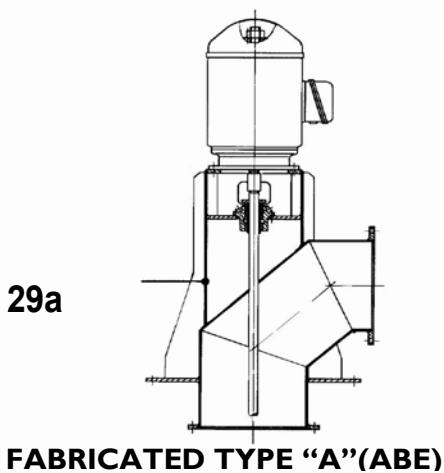

SPECIAL ARRANGEMENTS

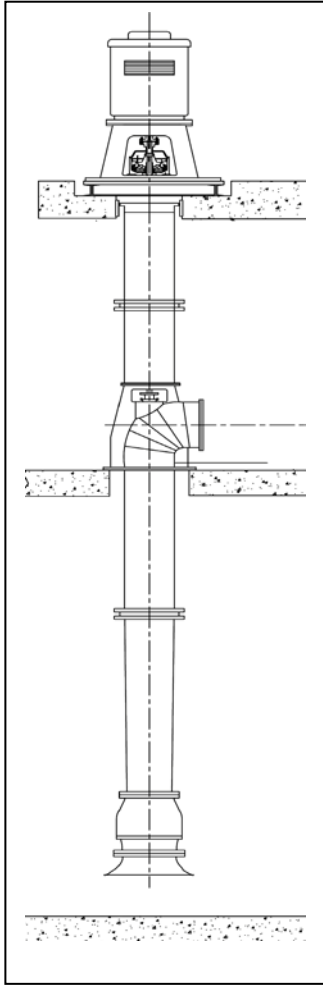

2 -Floor Arrangement

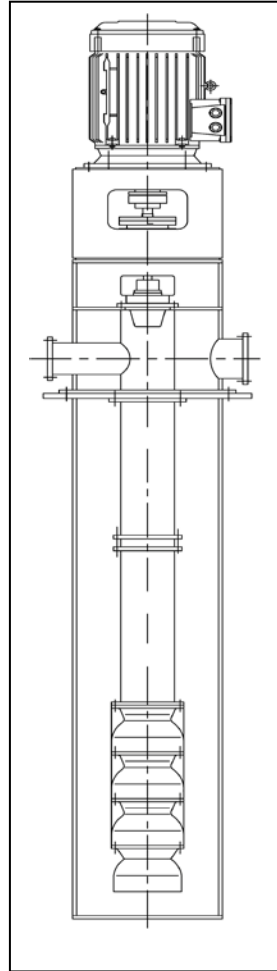

Can-Type Arrangement

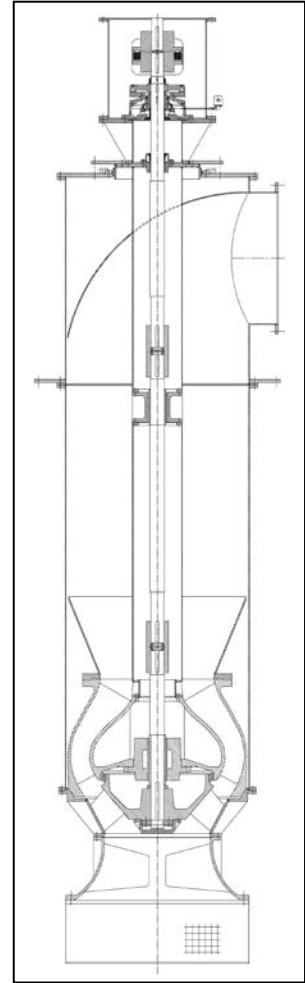

Pull-Out Arrangement

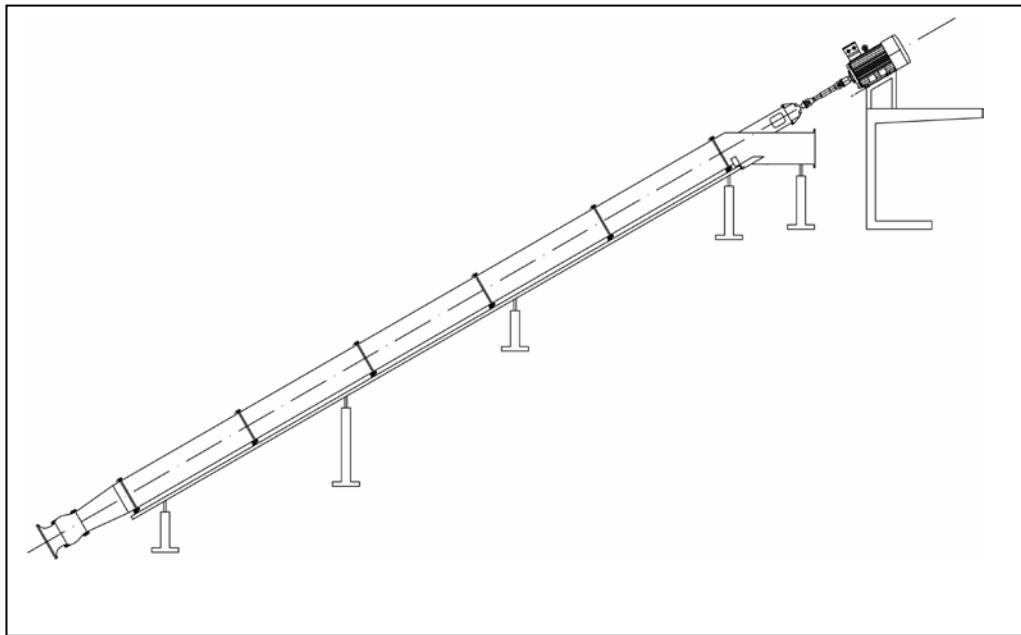

Inclined Arrangement

DIMENSIONS BOWL ASSEMBLY

All dimensions in mm

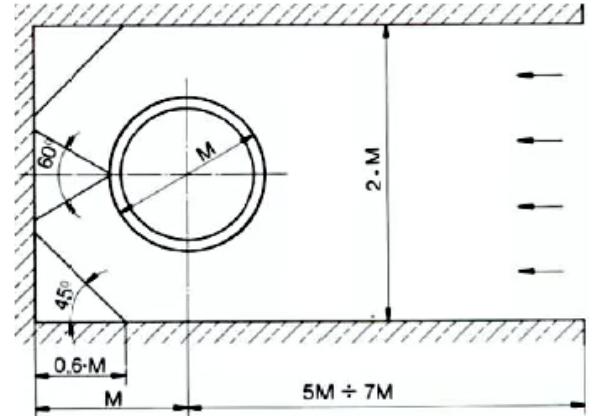
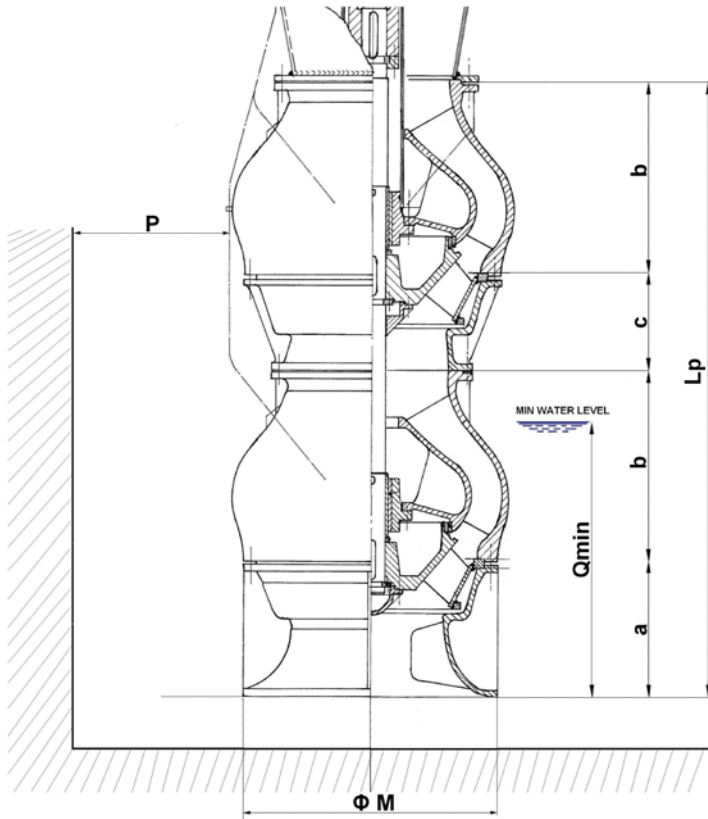

PUMP TYPE	NW STD PIPE	Ø M	Q Min *	P	a	b	c	BOWL ASSEMBLY LENGTH (Lp = a + b.n) No of stages (n)	
								1	2
340 D	400	575	1200	290	320	420	225	740	1385
480 D	600	800	1500	400	470	610	-	1080	1690
500 KMa	600	800	1700	400	483	477	163	960	1600
500 DL	600	880	1700	440	490	535	250	1045	1850
560 KRM	500	700	2000	350	440	365	105	910	1380
580 D	700	950	1800	475	520	710	380	1230	2320
680 D	900	1150	2000	575	640	840	450	1480	2770
590 F	1000	1170	2000	585	675	800	-	1475	
700 KRM	1000	1000	1700	500	600	500	162	1100	1762
850 KMa	1000	1440	2500	720	915	928	303	1843	
820 KQM	900	1450	2300	725	960	825	-	1785	
850 KQM	1000	1450	2400	725	960	920	-	1880	
850 D	1000	1435	2400	720	800	1050		1850	
920 D	1200	1560	2500	780	865	950	-	1815	
1320 D	1600	2235	3500	1120	1245	1360	-	2605	

DIMENSIONS DISCHARGE HEAD TYPE "A"

All dimensions in mm except where inches are indicated

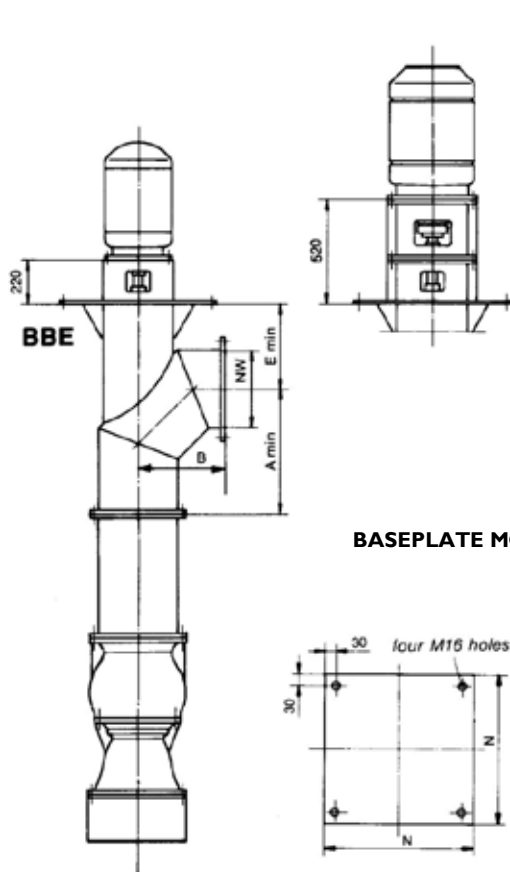

BASEPLATE MOUNTING

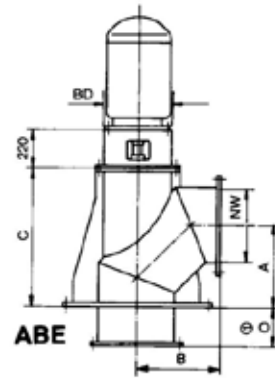

BD	NW	A	B	C	E min	N
10" - 12"	200	250	250	450	400	550
	250	300	300	520	450	650
	300	400	400	650	500	650
16.5" - 20"	300	400	400	650	500	650
	350	450	450	700	550	800
	400	500	500	800	600	900
	450	550	550	850	650	900
	500	550	550	900	650	900

DIMENSIONS



FABRICATED TYPE "C"

DRIVER MOUNTING FLANGE

BD	AJ	AK	BF
10" 12"	231.8	209.5	22.2
16.5" 20" 24.5"	374.6	342.9	17.5
30.5"	660.4	558.8	20.5

Driver mounting flange dimensions according to NEMA standards

Discharge flange dimensions according to DIN 2632 for 10 bar with exception of the thickness

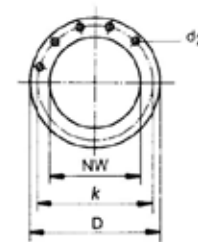

DISCHARGE FLANGE

NW	D	K	No of holes	d2
250	395	350	12	23
300	445	400	12	23
350	505	460	16	23
400	565	525	16	27
450	615	565	20	27
500	670	620	20	27

DIMENSIONS

DISCHARGE HEAD TYPE "B", "C", "D"

All dimensions in mm except where inches are indicated

FABRICATED TYPE "B"

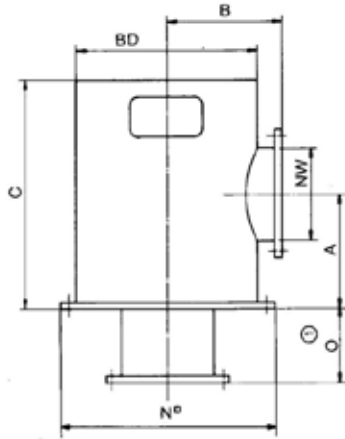

CASTED TYPE "D"

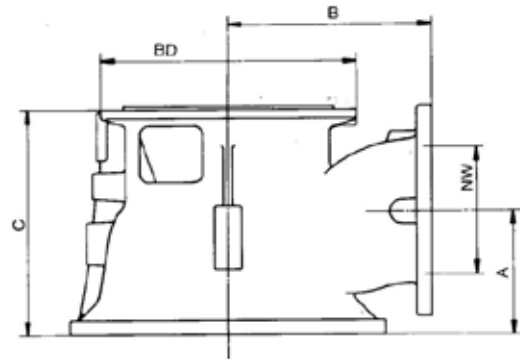

FABRICATED TYPE "C"

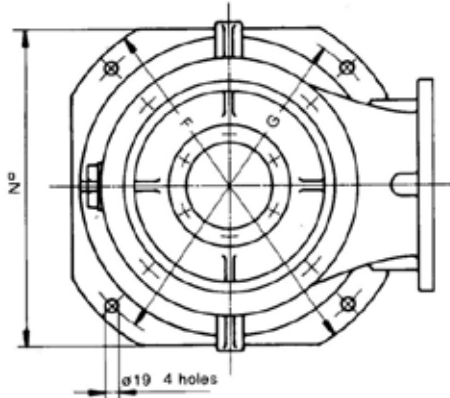
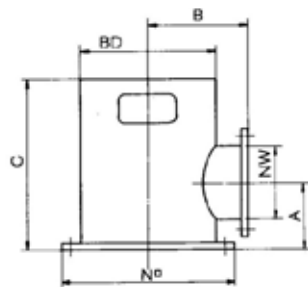

BD	NW	TYPE "B"				TYPE "C"				TYPE "D"						
		A	B	C	N ^p	A	B	C	N ^p	A	B	C	N ^p	Ø F	Ø G	
10" - 12"	200	250	350	600	650	200	250	530	500	200.2	330.2	386	508	597	539.8	
	250	300	350	650		250	350	580	600	235	355.6	425	533	636	577.9	
	300	400	400	800		280		640								
16.5" - 20"	200	250	350	600	650	220	350	530	600	200.2	330.2	386	508	597	539.8	
	250	300	350	650		250		580								
	300	400	400	800		280		640								
	350	450	450	850		800		700								
	400	500	500	900		900		340		750	700					
24.5"	200	250	350	650	700	220	350	530	650	200.2	330.2	386	508	597	539.8	
	250	300	350	700	700	250		580								
	300	400	400	800	800	280		640								
	350	450	450	850	800	310		700								
	400	500	500	900	900	340		750		700						
30.5"	250	300	400	700	900											
	300	400	400	800												
	350	450	450	850												
	400	500	500	900												
	450	550	550	950												

① The dimension O depends on customer requirement

ISO 9001
ISO 14001
OHSAS 18001
BUREAU VERITAS
Certification



Member of
Europump

HEAD OFFICE

16 KOLOKOTRONI St, KRYONERI, ATTICA, GREECE
TEL.: +30 210 8161402, FAX: +30 210 8161262
sales@dppumpsgroup.com
www.dppumps.global



WATER BRINGS LIFE. WE BRING WATER.